



3000-3S and 2600-2S Marker Option

Used with:

- 3000-3S 30' 3-Section Folding Drill
- 2600-2S 26' 2-Section Folding Drill



When you see this symbol, the subsequent instructions and warnings are serious - follow without exception. Your life and the lives of others depend on it!

Before You Start

These option assembly instructions contain only information on assembling the attachment to the main unit. A detailed Operator's Manual was supplied with the main unit when it was purchased. For more specific information on safety concerns refer to the Operator's Manual. Also included in the Operator's Manual is important information on operation, adjustment, troubleshooting, and maintenance for this attachment (some of these sections do not apply to all options).

A separate Parts Manual for replacement parts can be purchased from your dealer. Have model and serial numbers handy when placing an order.

Manual Part Numbers:

- 3000-3S 30' 3 Sec. Drill Operator's Manual195-110M
- 3000-3S 30' 3 Sec. Drill Parts Manual195-110P
- 2600-2S 26' 2 Sec. Drill Operator's Manual195-200M
- 2600-2S 26' 2-Sec. Drill Parts Manual195-200P

General Information

These option assembly instructions apply to the marker bundles listed below:

- 113-552A 3000-2600 Left Hand Flat Fold Marker Pkg. 96
- 113-553A 30' 3-Section Dual Flat Fold Marker Package 96
- 113-044A 3000-2600 Right Hand Flat Fold Marker Pkg

Starting on page 5 is a detailed listing of parts included in these kits. Use this list as a checklist to inventory parts received.

Assembly Instructions

Marker Assembly

NOTE: If installing right hand marker package to drill already equipped with left hand marker, follow instructions listed under "Dual Flat Fold Marker Hydraulic Assembly."

Refer to Figure 1:

1. Place drill in a lowered (field) position. From each end of drill box allow 16 ft. clearance for marker assembly.

Before mounting to drill with fertilizer attachment see "Drill with Fertilizer Attachment" on page 4.

2. Attach marker first section and mount assembly (1) to wing box frame. Marker mount should be assembled as far out-board on frame as possible. This places center of mount plate the distance (A) from end of box frame. Fasten using 5/8" x 6" x 7 3/4" u-bolts (18), 5/8" lock washers (19), and 5/8" hex nuts (20). Place marker first section in horizontal position by removing port plugs in hydraulic cylinders and completely extending cylinder rods. Always assemble marker in unfolded position.

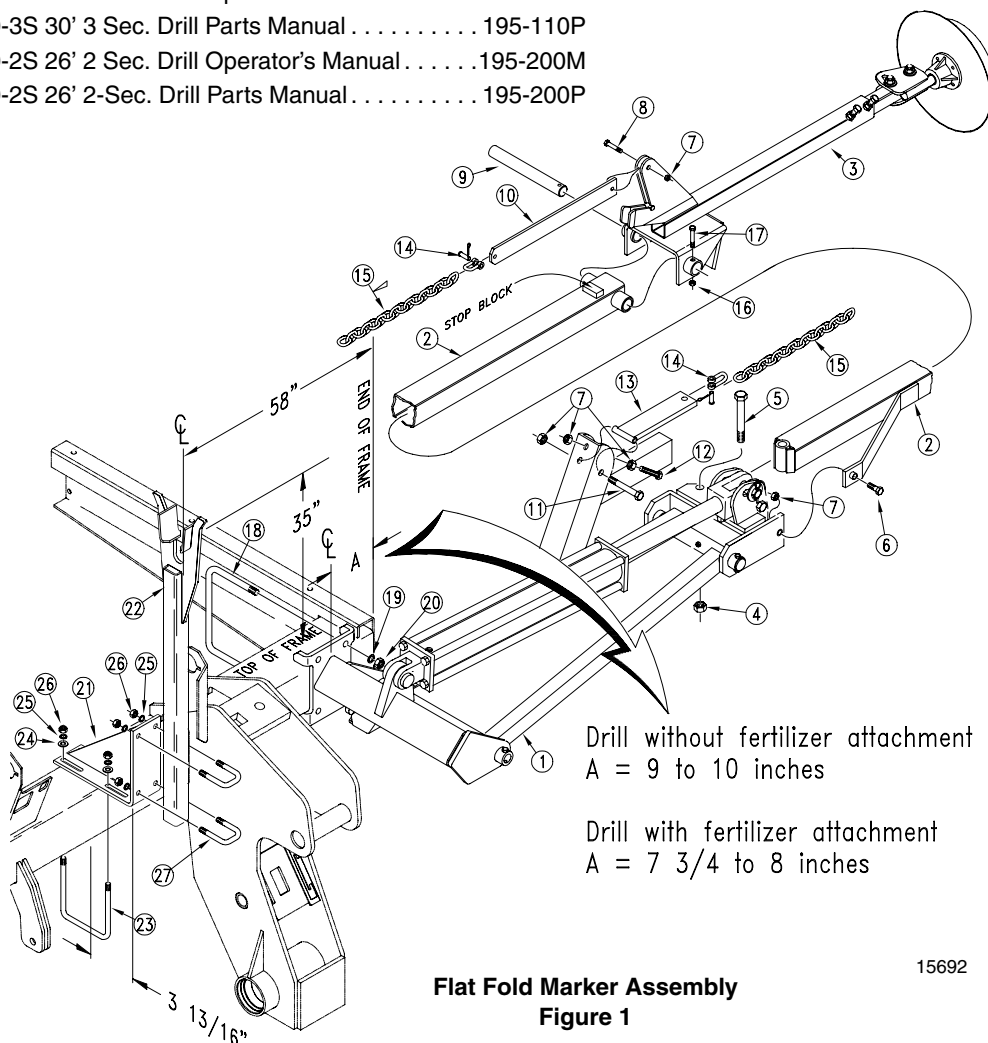

Flat Fold Marker Assembly
Figure 1

15692

Assembly Instructions

1. Assemble the second marker section (#2) to the first section (#1) with the 5/8" x 5 1/2" long bolt (#5), 5/8" lock nut (#4), 3/8" x 2" long grade 2 shear bolt (#6), and 3/8" lock nut (#7). The STOP BLOCK at outboard end of the second marker section (#2) must be POSITIONED ON TOP as shown in the illustration.
2. Place the third marker section (#3) over the end of the second section (#2) and insert 1" x 10 3/16" hinge pin (#9) through the second and third section pivot. Secure the hinge pin (#9) with the 1/4" x 2" long bolt (#17) and 1/4" lock nut (#16).
3. Bolt the chain bar weldment (#13) to the first marker section (#1) with 3/8" x 3 1/4" long bolt (#11) and 3/8" lock nut (#7). The chain bar weldment (#13) should pivot freely on the 3/8" bolt (#11). Bolt the chain bar (#10) to the third marker section with the 3/8" x 1 1/2" long bolt (#8) and 3/8" lock nut (#7). The chain bar (#10) should pivot freely on the 3/8" bolt (#8). Connect the marker chain (#15) between the chain bar (#10) and chain bar weldment (#13) with 5/16" utility clevises (#14). With the marker disk adjusted for seeding width and the disk touching the ground, adjust the chain length to remove the slack. The adjustment should be made at the utility clevis (#14) nearest to the drill.
4. The purpose of the 3/8" x 2 1/2" long full thread stop bolt (#12) is to hold tension on the marker chain (#15) ONLY when the marker is in the folded position. Therefore, the 3/8" stop bolt (#12) and 3/8" lock nuts (#7) should be assembled on the lift arm extension of section one (#1) so the head of the stop bolt extends down as little as possible. After the marker is bled and folded, adjust the stop bolt to remove the slack from the chain. Refer to the "Marker Chain Adjustments" of the OPERATOR'S MANUAL.
5. Assemble the marker transport mounts (#21) to the drill wing sections with the 1/2" x 6 x 7 1/4" long u-bolts (#23), 1/2" USS flat washers (#24), 1/2" lock washers (#25), and

1/2" hex nuts (#26). The transport mounts (#21) should be centered 58" in from the outer end of the box frame. Slide the mount forward so its leading edge is about 3 13/16" ahead of the front edge of the 6" x 6" box frame tube. The 3 13/16" dimension will position the mount close to the desired transport location, but additional centering adjustment may be needed when the marker is folded for the first time. Refer to the "Marker Transport Carrier Adjustments" of the OPERATOR'S MANUAL. The marker transport mount (#21) contains a cutout for routing hydraulic hoses through it. Disconnect the opener lift cylinder hoses at the inner opener lift cylinder and reroute the hoses through the opening in the marker transport mount. The marker hoses should also be routed through the mount.

6. Bolt the marker transport carrier (#22) to the transport mount (#21) with the 1/2" x 2 x 3" long u-bolts (#27), 1/2" lock washers (#25), and 1/2" hex nuts (#26). The marker rest saddle is not centered on the marker transport carrier (#22) and should be offset forward. The top surface of the saddle that the marker rests on should be approximately 35" above the top of the 6" x 6" box frame tube. The second marker section should be parallel with the seed box lid and centered in the saddle when the marker is folded. Adjust the marker carrier height when the drills is folded for the first time. Refer to the "Marker Transport Carrier Adjustments" of the OPERATOR'S MANUAL.

Single Flat Fold Marker Hydraulic Assembly

Refer to Figure 2:

1. Assemble elbows (#2) to the hydraulic cylinder ports.
2. Assemble 3/8" MNPT adapter (#6) and needle valve (#7) to the rod end elbow fitting.

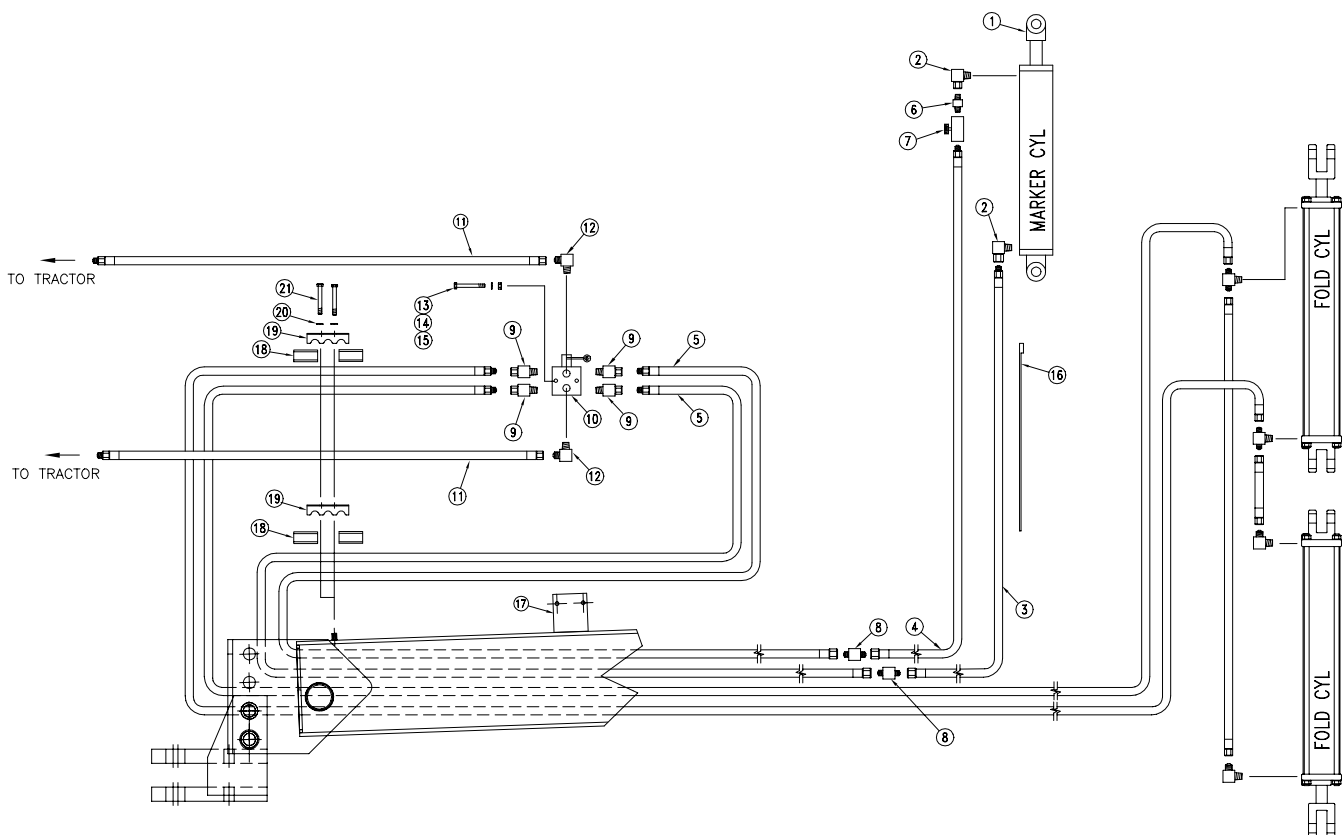

15685

Single Marker Hydraulics
Figure 2

Assembly Instructions

- Route 252" long hose (#3) from the center of the drill to the marker base end fitting. Route 272" long hose (#4) from the center of the drill to the needle valve (#7) at the marker rod end fitting. Route the marker hoses along the same path as the opener lift hoses, allowing the same slack at the drill toolbar pivots as the other hoses. Use the rubber hose protectors and hose clamp brackets which are already bolted to your drill to secure the hoses in place. **DO NOT** alter the routing or amount of hose slack of the existing hoses when you loosen the clamp brackets to insert the marker hoses. Tie the marker hoses to the opener lift hoses at the toolbar vertical and horizontal pivots with cable ties (#16).
- Route the 348" long hoses (#5) down the center of the tongue tube and connect them to the hoses (#3) and (#4) with JIC adapters (#8) at the center of the center box section. Make sure the hoses do not interfere with the center clutch assembly.
- Bolt the selector valve (#10) to the valve mount bracket (#17) on the tongue tube with the 3/8" x 3 1/4" long bolts (#13), 3/8" lock washers (#14), and 3/8" hex nuts (#15). Install the 1/2" FNPT adapters (#9) to the front and rear ports of the selector valve (#10) and the 3/4" JIC elbows (#12) to the cross ports. Assemble the 96" long 3/8" hoses (#11) to the elbows (#12) on the selector valve.
- Connect the 348" long hoses (#5) to the rear adapters on the selector valve (#10). Connect the long hoses from the fold hydraulic circuit to the front adapters on the selector valve. Secure the four 1/4" hoses going into the selector valve to the top of the tongue with the hydraulic hose guards (#18), the hose clamp brackets (#19), the 5/16" x 2 1/2" bolts (#21), and 5/16" lock washers (#20). The 5/16" bolts screw into the nuts which are welded to the top of the tongue tube.
- Tie the hoses down with plastic cable ties (#16) to prevent pinching or kinking of hoses during the folding operation. Tying the hydraulic hoses to the marker mount tube as shown in Figure 3 is the preferred way to assure that they will flex properly and not get pinched by the marker first section.

IMPORTANT: BEFORE FOLDING THE MARKER, BLEED ALL THE AIR OUT OF THE HYDRAULIC SYSTEM.

- Bleed the marker hydraulic system as described in the drill **OPERATOR'S MANUAL**.
- Set the marker raise and lower speeds as described in the drill **OPERATOR'S MANUAL**.

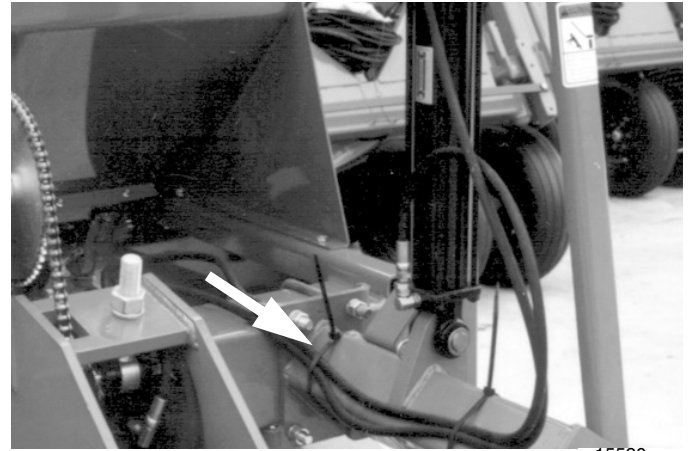

Hydraulic Hose Routing at Marker Mount
Figure 3

15530

Dual Flat Fold Marker Hydraulic Assembly

Refer to Figure 4:

- Assemble elbows (#2) to the hydraulic cylinder ports.
- Route 272" long hoses (#3) from the center of the drill to the marker rod end fittings. Route 252" long hose (#4) from the center of the drill to the marker base end fitting. Route the marker hoses along the same path as the opener lift hoses,

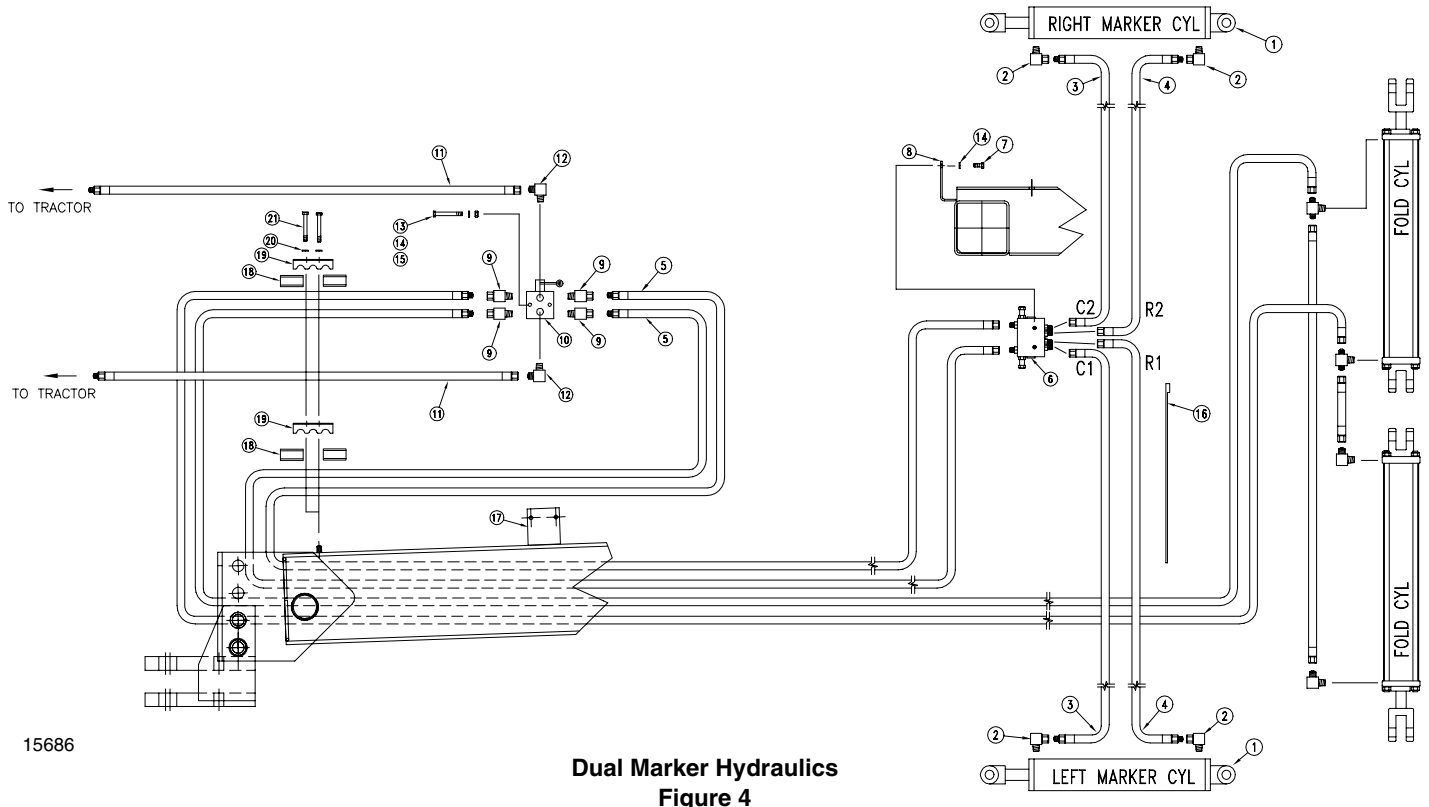

15686

Dual Marker Hydraulics
Figure 4

Assembly Instructions

allowing the same slack at the drill toolbar pivots as the other hoses. Use the rubber hose protectors and hose clamp brackets which are already bolted to your drill to secure the hoses in place. DO NOT alter the routing or amount of hose slack of the existing hoses when you loosen the clamp brackets to insert the marker hoses. Tie the marker hoses to the opener lift hoses at the toolbar vertical and horizontal pivots with cable ties (#16).

3. Bolt the sequence valve (#6) to the valve mount bracket (#8) on the center of the center box frame with the 3/8" x 3/4" long bolts (#7), and 3/8" lock washers (#14). Mount the sequence valve (#6) so the side with four ports is up.
4. Connect the 272" long hose from the rod end of the left marker cylinder to the port marked "C1" on top of the sequence valve. Connect the 252" long hose from the base end of the left marker cylinder to the port marked "R1" on top of the sequence valve. Connect the 272" long hose from the rod end of the right marker cylinder to the port marked "C2" on top of the sequence valve. Connect the 252" long hose from the base end of the right marker cylinder to the port marked "R2" on top of the sequence valve.
5. Route the 348" long hoses (#5) down the center of the tongue tube and connect them to the adapters on the bottom side of the sequence valve (#6). Make sure the hoses do not interfere with the center box frame clutch assembly.
6. Bolt the selector valve (#10) to the valve mount bracket (#17) on the tongue tube with the 3/8" x 3 1/4" long bolts (#13), 3/8" lock washers (#14), and 3/8" hex nuts (#15). Install the 1/2" FNPT adapters (#9) to the front and rear ports of the selector valve (#10) and the 3/4" JIC elbows (#12) to the cross ports. Assemble the 96" long 3/8" hoses (#11) to the elbows (#12) on the selector valve.
7. Connect the 348" long hoses (#5) to the rear adapters on the selector valve (#10). Connect the long hoses from the fold hydraulic circuit to the front adapters on the selector valve. Secure the four 1/4" hoses going into the selector valve to the top of the tongue with the hydraulic hose guards (#18), the hose clamp brackets (#19), the 5/16" x 2 1/2" bolts (#21), and 5/16" lock washers (#20). The 5/16" bolts screw into the nuts which are welded to the top of the tongue tube.
8. Tie the hoses down with plastic cable ties (#16) to prevent pinching or kinking of hoses during the folding operation. Tying the hydraulic hoses to the marker mount tube as shown in Figure 3 is the preferred way to assure that they will flex properly and not get pinched by the marker first section.

IMPORTANT! BEFORE FOLDING THE MARKER, BLEED ALL THE AIR OUT OF THE HYDRAULIC SYSTEM.

9. Bleed the marker hydraulic system as described in the drill OPERATOR'S MANUAL.
10. Set the marker raise and lower speeds as described in the drill OPERATOR'S MANUAL.

Drill with Fertilizer Attachment

Refer to Figure 5:

If the drill has a fertilizer attachment, move the drive mount angle iron, as shown, before mounting markers.

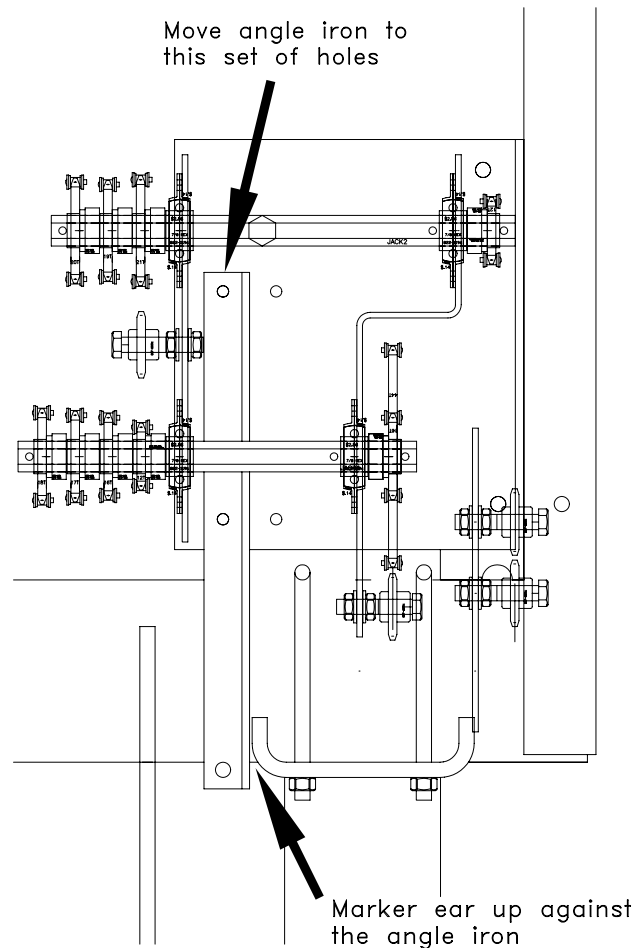

**Angle Iron for fertilizer Attachment
Figure 5**

Listing of Parts

113-552A 3000-2600 Left Hand Flat Fold Marker Package 96

Your Kit Includes:

Qty.	Part No.	Part Description
1	113-554K	30' 3-SEC LH FF MARKER BUNDLE (Includes:)
1		MARKER MOUNT AND FIRST SECTION SUBASSEMBLY
1		MARKER SECOND SECTION SUBASSEMBLY
1		MARKER THIRD SECTION SUBASSEMBLY
1	113-200H	CHAIN BAR WELDMENT
1	113-323D	CHAIN BAR
1	113-560H	MARKER CARRIER
1	113-568H	MARKER TRANSPORT MOUNT
1	113-555K	30' 3-SEC LH FF MARKER HARDWARE (Includes:)
1	113-311D	HINGE PIN
1	113-319D	MARKER CHAIN 30'
4	113-370D	1/4 MARKER HYD HOSE GUARD
1	113-561M	MANUAL 30' 3-SEC MARKERS
2	196-112D	HOSE CLAMP BRACKET
6	800-082C	CABLE TIE 21" LONG
1	802-022C	HHCS 3/8-16X1 1/2 GR5
1	802-115C	HHCS 5/16-18X2 GR5
3	802-168C	HHCS 3/8-16X3 1/4 GR5
2	802-172C	HHCS 5/16-18X2 1/2 GR5
1	802-261C	HHCS 3/8-16X2 1/2 GR5 FTTHD
1	803-011C	NUT LOCK 5/16-18 PLT
3	803-013C	NUT LOCK 3/8-16 PLT
2	803-014C	NUT HEX 3/8-16 PLT
8	803-020C	NUT HEX 1/2-13 PLT
4	803-021C	NUT HEX 5/8-11 PLT
2	804-009C	WASHER LOCK SPRING 5/16 PLT
2	804-011C	WASHER FLAT 3/8 USS PLT
2	804-013C	WASHER LOCK SPRING 3/8 PLT
8	804-015C	WASHER LOCK SPRING 1/2 PLT
4	804-017C	WASHER FLAT 1/2 USS PLT
4	804-022C	WASHER LOCK SPRING 5/8 PLT
2	806-005C	U-BOLT 1/2-13 X 2 X 3 GR 5
2	806-039C	U-BOLT 5/8-11 X 6 1/32 X 7 3/4
2	806-060C	U-BOLT 1/2-13 X 6 1/32 X 7 1/4
1	810-058C	VALVE 3/8 NEEDLE
1	810-274C	DOUBLE SELECTOR VALVE 3/4FORB
4	811-021C	AD 1/2FNPTS 3/4MORB
1	811-044C	AD 3/8MNPT
2	811-171C	EL 3/4MORB 9/16MJIC
2	811-281C	EL 3/8FNPT 9/16MORB
2	811-315C	AD 9/16MJIC
2	890-018C	UTILITY CLEVIS 5/16
1	113-629V	24' 2SNT DUAL W/SEQ HOSE BNDL (Includes:)
1	811-035C	HH1/4R1 252 9/16FJIC 3/8MNPT
1	811-293C	HH1/4R1 272 3/8MNPT 9/16FJIC
2	811-579C	HH3/8R1 096 1/2MNPT 9/16FJIC
2	811-580C	HH1/4R1 348 1/2MNPT 9/16FJIC

Listing of Parts

113-553A 30' 3 Section Dual Flat Fold Marker Package 96

Your Kit Includes:

Qty.	Part No.	Part Description
1	113-556K	30' 3-SEC DUAL FF MARKER BNDLE (Includes:)
1		RIGHT HAND MARKER MOUNT AND FIRST SECTION SUBASSEMBLY
1		RIGHT HAND MARKER SECOND SECTION SUBASSEMBLY
1		LEFT HAND MARKER MOUNT AND FIRST SECTION SUBASSEMBLY
1		LEFT HAND MARKER SECOND SECTION SUBASSEMBLY
2		MARKER THIRD SECTION SUBASSEMBLY
2	113-200H	CHAIN BAR WELDMENT
2	113-323D	CHAIN BAR
2	113-560H	MARKER CARRIER
2	113-568H	MARKER TRANSPORT MOUNT
1	113-557K	30' 3-SEC DUAL FF MARKER HARDWARE (Includes:)
2	113-311D	HINGE PIN
2	113-319D	MARKER CHAIN 30'
4	113-370D	1/4 MARKER HYD HOSE GUARD
1	113-561M	MANUAL 30' 3-SEC MARKERS
2	196-112D	HOSE CLAMP BRACKET
12	800-082C	CABLE TIE 21" LONG
2	802-014C	HHCS 3/8-16X3/4 GR5
2	802-022C	HHCS 3/8-16X1 1/2 GR5
2	802-115C	HHCS 5/16-18X2 GR5
4	802-168C	HHCS 3/8-16X3 1/4 GR5
2	802-172C	HHCS 5/16-18X2 1/2 GR5
2	802-261C	HHCS 3/8-16X2 1/2 GR5 FTHD
2	803-011C	NUT LOCK 5/16-18 PLT
8	803-013C	NUT LOCK 3/8-16 PLT
2	803-014C	NUT HEX 3/8-16 PLT
16	803-020C	NUT HEX 1/2-13 PLT
8	803-021C	NUT HEX 5/8-11 PLT
2	804-009C	WASHER LOCK SPRING 5/16 PLT
4	804-011C	WASHER FLAT 3/8 USS PLT
6	804-013C	WASHER LOCK SPRING 3/8 PLT
16	804-015C	WASHER LOCK SPRING 1/2 PLT
8	804-017C	WASHER FLAT 1/2 USS PLT
8	804-022C	WASHER LOCK SPRING 5/8 PLT
4	806-005C	U-BOLT 1/2-13 X 2 X 3 GR 5
4	806-039C	U-BOLT 5/8-11 X 6 1/32 X 7 3/4
4	806-060C	U-BOLT 1/2-13 X 6 1/32 X 7 1/4
1	810-197C	VALVE,SEQUENCE SHOEMAKER
1	810-274C	DOUBLE SELECTOR VALVE 3/4FOR
4	811-021C	AD 1/2FNPTS 3/4MORB
2	811-171C	EL 3/4MORB 9/16MJIC
4	811-281C	EL 3/8FNPT 9/16MORB
4	890-018C	UTILITY CLEVIS 5/16
1	113-631V	30' 3SEC DUAL FF HOSE BUNDLE (Includes:)
2	811-035C	HH1/4R1 252 9/16FJIC 3/8MNPT
2	811-293C	HH1/4R1 272 3/8MNPT 9/16FJIC
2	811-579C	HH3/8R1 096 1/2MNPT 9/16FJIC
2	811-580C	HH1/4R1 348 1/2MNPT 9/16FJIC

Listing of Parts

113-044A 3000-2600 Right Hand Flat Fold Marker Package

Your Kit Includes:

Qty.	Part No.	Part Description
1	113-460K	3-SEC FF MARKER ARM ASSY (Includes:)
1	113-182H	2ND SECTION
1	113-183H	30' FF MARKER 3RD SECTION
1	113-323D	CHAIN BAR
1	113-351D	MARKER TUBE 42 LG
1	113-563S	MARKER DISC & HUB ASSEMBLY
1	800-001C	GREASE ZERK STRAIGHT 1/4-28
2	801-054C	SCREW SET SQ HD 1/2-13 X 1
1	802-022C	HHCS 3/8-16 X 1 1/2 GR 5
2	802-039C	HHCS 1/2-13 X 3 GR 5
1	802-266C	HHCS 3/8-16 X 2 GR 2
2	803-013C	NUT LOCK 3/8-16 PLT
2	803-020C	NUT HEX 1/2-13 PLT
2	803-036C	NUT HEX JAM 1/2-13 PLT
2	804-011C	WASHER FLAT 3/8 USS PLT
2	804-015C	WASHER LOCK SPRING 1/2 PLT
4	804-017C	WASHER FLAT 1/2 USS PLT
1	113-046K	3000-2600 RH FF MARKER HRDW (Includes:)
1	113-311D	HINGE PIN
1	113-319D	CHAIN COIL 1/4 HIGH TEST 61
1	113-560H	MARKER CARRIER
1	113-568H	MARKER TRANSPORT MOUNT
1	196-146D	3-HOSE CLAMP BRACKET
6	800-082C	CABLE TIE .31 X 21.5 6 DIA 120
2	802-012C	HHCS 5/16-18 X 1 1/2 GR 5
2	802-014C	HHCS 3/8-16 X 3/4 GR 5
1	802-115C	HHCS 5/16-18 X 2 GR 5
2	802-261C	HHCS 3/8-16 X 2 1/2 GR 5 FTHD
1	803-011C	NUT LOCK 5/16-18 PLT
4	803-013C	NUT LOCK 3/8-16 PLT
8	803-020C	NUT HEX 1/2-13 PLT
4	803-021C	NUT HEX 5/8-11 PLT
4	804-013C	WASHER LOCK SPRING 3/8 PLT
8	804-015C	WASHER LOCK SPRING 1/2 PLT
4	804-017C	WASHER FLAT 1/2 USS PLT
4	804-022C	WASHER LOCK SPRING 5/8 PLT
2	806-005C	U-BOLT 1/2-13 X 2 X 3 GR 5
2	806-039C	U-BOLT 5/8-11 X 6 1/32 X 7
2	806-060C	U-BOLT 1/2-13 X 6 1/32 X 7
1	810-197C	VALVE, SEQUENCE SHOEMAKER
2	811-281C	EL 3/8 FNPT 9/16 MORB
4	890-178C	SCREW PIN ANCHOR SHACKLE
1	113-047K	3000-2600 RH FF MARKER BUNDLE (Includes:)
1	113-188H	RH FIRST SECTION
1	113-189H	LIFT LUG CHANNEL RH
1	113-200H	CHAIN BAR WELDMENT
1	113-248D	PIN 1 OD X 4.41 USABLE
1	113-312D	FIRST PIVOT SHAFT
1	113-313D	SECOND PIVOT SHAFT
1	113-324D	CYLINDER STOP
2	113-325D	STOP BUSHING
1	113-559H	MARKER, RH MOUNT 96
2	800-001C	GREASE ZERK STRAIGHT 1/4-28
2	802-115C	HHCS 5/16-18 X 2 GR 5
1	802-168C	HHCS 3/8-16 X 3 1/4 GR 5
1	802-249C	HHCS 1/2-13 X 4 1/2 GR 5 SPTH
1	802-254C	HHCS 5/8-11 X 5 1/2 GR 5
2	803-011C	NUT LOCK 5/16-18 PLT

Listing of Parts**113-044A 3000-2600 Right Hand Flat Fold Marker Package (Cont.)***Your Kit Includes:*

Qty.	Part No.	Part Description
1	803-019C	NUT LOCK 1/2-13 PLT
1	803-024C	NUT LOCK 5/8-11 PLT
2	804-029C	WASHER FLAT 1 SAE
2	805-058C	PIN COTTER 3/16 X 2
1	810-118C	CYL 2.5 X 20 X 1.12 ROD
2	818-682C	DECAL WARNING PINCH/CRUSH
1	113-045V	3000-2600 RH HOSE BUNDLE (Includes:)
1	811-035C	HH1/4R1 252 9/16 FJIC 3/8 MNP
1	811-293C	HH1/4R1 272 3/8 MNPT 9/16 FJI

Great Plains Manufacturing, Inc.

**Corporate Office: P.O. Box 5060
Salina, Kansas 67402-5060 USA**
