

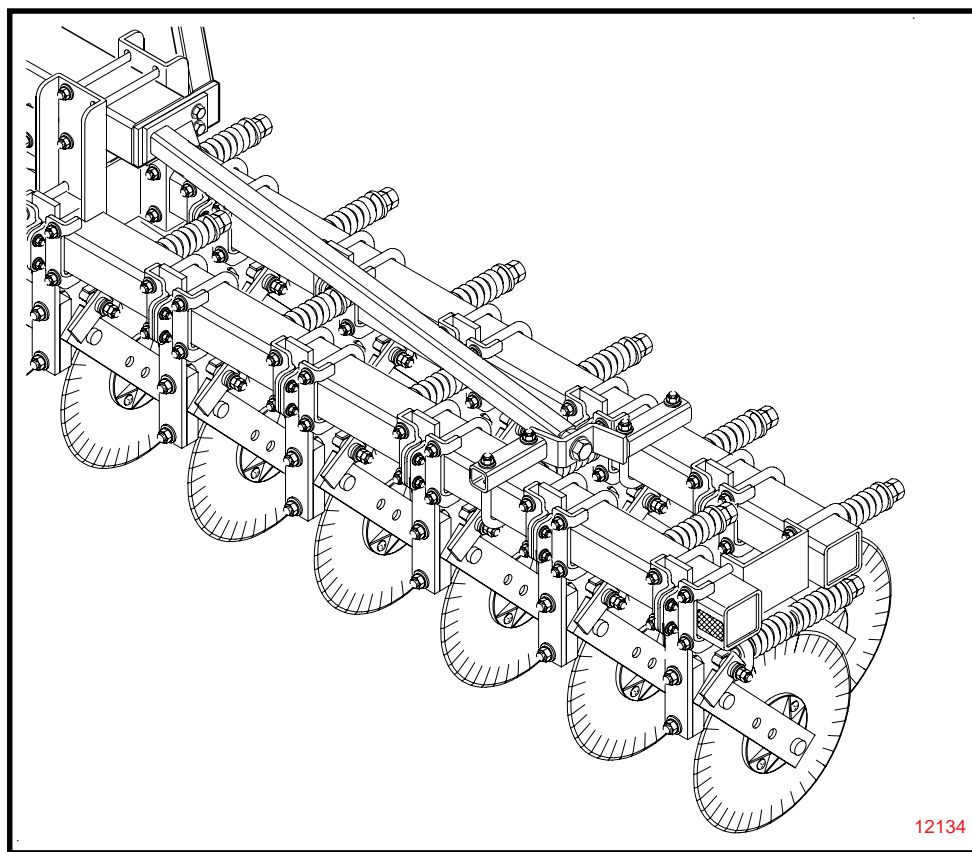

1994 20' CPH
Coulter Tool Bar
Brace Assembly



12134

General Information

Important Notice

Great Plains Manufacturing, Inc. provides this publication "as is" without warranty of any kind, either express or implied, while every precaution has been taken in the preparation of this manual, Great Plains Manufacturing, Inc. assumes no responsibility for errors or omissions. Neither is any liability assumed for damages resulting from the use of the information contained herein. Great Plains Manufacturing, Inc. reserves the right to revise and improve its products as it sees fit. This publication describes the state of this product at the time of its publication, and may not reflect the product at all times in the future.

This publication, or parts thereof, may not be reproduced in any form, by any method, for any purpose without written permission from Great Plains Manufacturing, Inc.

Great Plains Manufacturing, Inc. Trademarks

The following are registered trademarks of Great Plains Manufacturing, Inc. Great Plains, Land Pride, Application Systems, MeterCone, and Whirlfilter.

Printed in the United States of America.

For your convenience, record the information listed in the spaces provided below. Have this information before you when calling Great Plains Manufacturing, Inc.

This Operator's Manual applies to:

149-169A

20' CPH Coulter Tool Bar Brace Assembly

Owner's Information

Name: _____

Name of Dealership _____

Address _____

Dealer's Name _____

City _____ State ____ Zip

Address _____

Phone _____

City _____ State ____ Zip

Phone _____

Date Purchased _____

Great Plains Manufacturing, Inc.

Table of Contents

Introduction	1	Assembling The Coultter Tool Bar Brace Assembly	3
Using This Manual	1	Post-Assembly Checklist	3
Section 1 Safety	2	Section 3 Basic Operation	3
Section 2 Assembly Instructions & Set-Up	2	Section 4 Parts Book	4
Torque Values Chart.....	2	Coultter Tool Bar Brace Assembly	4
Pre-Assembly Checklist	3		

Introduction

This manual has been prepared to instruct you in the safe and efficient operation of your **1994 20' CPH Coultter Tool Bar Brace Assembly**. Read and follow all instructions and safety precautions carefully.

The parts on your **1994 20' CPH Coultter Tool Bar Brace Assembly** have been specially designed and should only be replaced with genuine **Great Plains** parts. Therefore; should your **Coultter Tool Bar Brace Assembly** require replacement parts, go to your **Great Plains Dealer**.

The right hand and left hand as used throughout this manual is determined by facing in the direction the machine will travel when in use unless otherwise stated.

Product Overview

The Great Plains Coultter Tool Bar Brace Assembly is designed to enhance the performance of your Center Pivot Hitch in extremely hard soil conditions by reducing the upward flex on the ends of the 20' coultter tool bars, thus giving better coultter depth control.

This assembly is not needed and will not fit on a CPH with the coultter tool bar weight brackets assembled on the end of the coultter tool bars.



The SAFETY ALERT SYMBOL indicates that there is a potential hazard to personal safety involved and extra safety precautions must be taken. When you see this

symbol, be alert and carefully read the message that follows it. In addition to design and configuration of equipment; hazard control and accident prevention are dependent upon the awareness, concern, prudence and proper training of personnel involved in the operation, transport, maintenance and storage of equipment.

Watch for the following safety notations throughout your Operators Manual and on your Center Pivot Hitch:

DANGER!

Indicates an imminently hazardous situation which, if not avoided, will result in death or serious injury. This signal word is limited to the most extreme situations.

WARNING!

Indicates a potentially hazardous situation which, if not avoided, could result in death or serious injury.

CAUTION!

Indicates a potentially hazardous situation which, if not avoided, may result in minor or moderate injury. It may also be used to alert against unsafe practices.

NOTE: Indicates a special point of information which requires your attention.

Using this Manual

Included with your **1994 20' CPH Coultter Tool Bar Brace Assembly** are the Operator's and the Parts Manual.

For your safety and to help in developing a better understanding of your equipment we highly recommend that you read the operator sections of this manual. Reading these sections not only provides valuable training but

also familiarizes you with helpful information and its location. The parts sections are for reference only and don't require cover to cover reading. After reviewing the manuals store them in a dry, easily accessible location for your future reference.

Section 1 Safety

Most accidents are the result of negligence and carelessness, usually caused by failure of the operator to follow simple but necessary safety precautions. The following safety precautions are suggested to help prevent such accidents. The safe operation of any machinery is a big concern to consumers and manufacturers. Your **1994 20' CPH Coulter Tool Bar Brace Assembly** has been designed with many built-in safety features. However, no one should operate this product before carefully reading this Operator's Manual.

1. Always set the drill in field position before lubrication, making adjustments, or servicing. Periodically check bolts for tightness and lubricate all fittings.
2. Do not lubricate or adjust the drill or hitch while it is in operation.
3. Never unhook hitch from tractor when attached to a raised drill.

4. Use extreme caution when unhitching implement from tractor. Negative tongue weight may cause immediate elevation of the tongue resulting in damage or personal injury.
5. Do not allow anyone to operate the machine who has not been properly trained in its safe operation.
6. Consult your drill & hitch operator's manual for safe operation..

Section 2 Assembly Instructions & Set-Up

Torque Values Chart

Bolt head identification marks are as per grade.

NOTE: Manufacturing marks will vary.

Bolt Size in mm		Grade 2				Grade 5				Grade 8*			
		Foot Pounds		Newton-Meters		Foot Pounds		Newton-Meters		Foot Pounds		Newton-Meters	
in	mm	Min.	Max.	Min.	Max.	Min.	Max.	Min.	Max.	Min.	Max.	Min.	Max.
1/4"	6.35	5	6	6.8	8.13	9	11	12.2	14.9	12	15	16.3	20.3
5/16"	7.94	10	12	13.6	16.3	17	20.5	23.1	27.8	24	29	32.5	39.3
3/8"	9.53	20	23	27.1	31.2	35	42	47.5	57.0	45	54	61.0	73.2
7/16"	11.11	30	35	40.7	47.4	54	64	73.2	86.8	70	84	94.9	113.9
1/2"	12.70	45	52	61.0	70.5	80	96	108.5	130.2	110	132	149.2	179.0
9/16"	14.29	65	75	88.1	101.6	110	132	149.2	179.0	160	192	217.0	260.4
5/8"	15.88	95	105	128.7	142.3	150	180	203.4	244.1	220	254	298.3	358.0
3/4"	19.05	150	185	203.3	250.7	270	324	366.1	439.3	380	456	515.3	618.3
7/8"	22.23	160	200	216.8	271.0	400	480	542.4	650.9	600	720	813.6	976.3
1"	25.40	250	300	338.8	406.5	580	696	786.5	943.8	900	1080	1220.4	1464.5
1 1/8"	25.58					800	880	1084.8	1193.3	1280	1440	1735.7	1952.6
1 1/4"	31.75					1120	1240	1518.7	1681.4	1820	2000	2467.9	2712.0
1 3/8"	34.93					1460	1680	1979.8	2278.1	2380	2720	3227.3	3688.3
1 1/2"	38.10					1940	2200	2630.6	2983.2	3160	3560	4285.0	4827.4

NOTE: These values apply to fasteners as received from supplier, dry, or when lubricated with normal engine oil They do not apply if special graphite or molydisulphide greases or other extreme pressure lubricants are used. This applies to both UNF and UNC threads.

* Thick nuts must be used with Grade 8 bolts

NOTE: Torque requirements listed above do not apply to self-locking nuts. For self-locking nuts increase the torque requirements listed by 15%.

Read and understand the owner's manual for your Center Pivot Hitch. A basic understanding of how the hitch works will aid in the assembly and setup of your Tool Bar Brace assemblies.

The following information is general in nature and was written to aid the operator in preparation of the tractor and hitch for use, and to provide general operating procedures. The operator's experience, familiarity with the machine and the following information should combine for efficient hitch operation and good working habits. Having all the parts and equipment readily at hand will speed up your assembly task and make the job as safe as possible.

Pre-Assembly Checklist

Check	Reference
<input type="checkbox"/> All major components	Section 2 Page 5
<input type="checkbox"/> Fasteners that were shipped with the package. NOTE: Some of the hardware from the factory may have been installed in the location where it will be used.	Section 2 Page 5
<input type="checkbox"/> If you are unsure where a fastener is used, use the parts section of this manual to identify it. Be sure the part gets used in the correct location.	Parts Manual

Assembling The Coultter Tool Bar Brace Assembly

For the following assembly instructions, refer to the illustration on page 4 section 4.

1. Set the Center Pivot Hitch down with the coultters just touching the ground, in a clear level area.

2. Assemble the right & left hand tool bar brace (#1) to the tool bar support end cap on the Center Pivot Hitch with the 3/4" x 2" long bolts (#2), 3/4" lock washers (#3), and the 3/4" hex nuts (#4). DO NOT tighten bolts yet.
3. Assemble the tool bar support weldment (#5) to the end of the tool bar support brace (#1) with the 1 1/4" x 2 1/2" long bolt (#10) and lock washer (#9). DO NOT tighten bolts yet. The tool bar support weldment (#5) is designed to be turned two different directions to keep from interfering with coultter clamps on the various coultter row spacings. Turn the tool bar support weldment as needed to assemble it to the support brace and miss the coultter clamps. On some row spacings, the access to the 1 1/4" x 2 1/2" long bolt may be limited because of coultter locations. In these situations, preassemble the tool bar support weldment (#5) to the tool bar brace (#1).
4. Fasten the tool bar support weldments (#5) to the coultter tool bars with the 5/8" x 4 1/32" x 7" u-bolts (#6), 5/8" lock washer (#7), and the 5/8" hex nut (#8). DO NOT tighten bolts yet.
5. Tighten the 1 1/4" x 2 1/2" long bolts first. Second, tighten the 3/4" x 2" long bolts at the top of the tool bar brace. Tighten the nuts on the 5/8" x 4 1/32" x 7" long u-bolts last.

Post-Assembly Checklist

Check
<input type="checkbox"/> "Safety Rules" in this Manual & in the CPH & drill Manuals.
<input type="checkbox"/> Drill & Hitch; initially and periodically for loose bolts, pins, and chains.
<input type="checkbox"/> All working parts are moving freely, bolts are tight and cotter pins are spread.
<input type="checkbox"/> CAUTION! Be familiar with the term NEGATIVE TONGUE WEIGHT . Be aware of the special precautions you should take when working with an implement that can develop Negative Tongue Weight.

Section 3 Basic Operation

CAUTION!

This Center Pivot Hitch should NEVER be pulled faster than 20 miles per hour!

The Coultter Tool Bar Brace Assembly is only needed for extremely hard soil conditions where some upward flex

may occur on the ends of a 20' Coultter Tool Bar. This assembly is not needed and will not fit on a Center Pivot Hitch with coultter tool bar weight brackets assembled on the ends of the coultter tool bars. On 20' units an operator can install Coultter Tool Bar Weight Bracket or Coultter Tool Bar Brace Kit, but not both.

Section 4 Coulter Tool Bar Brace Assembly

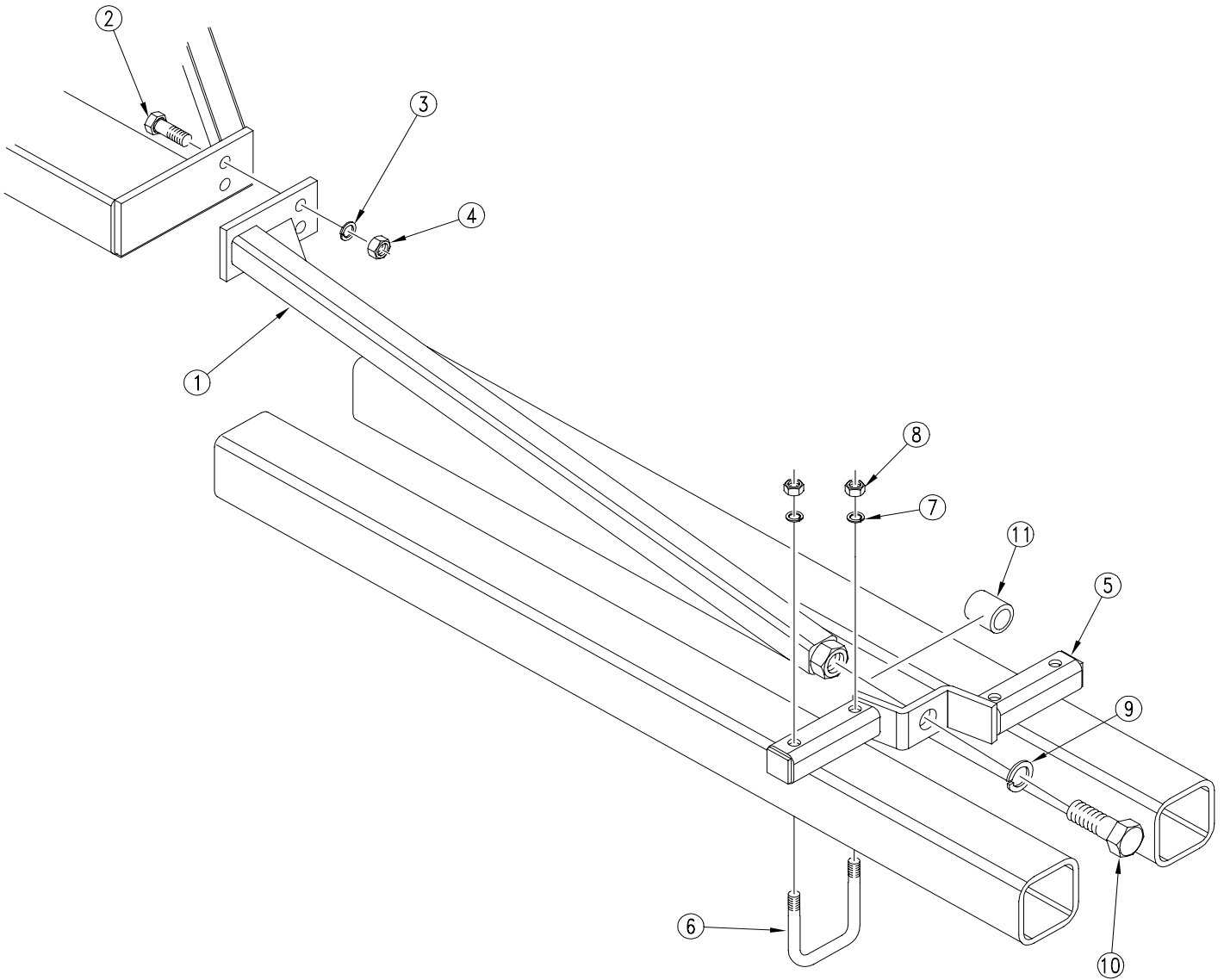

11979

Section 4 Coulter Tool Bar Brace Assembly

Ref.	Part No.	Part Description
1.	149-166H	20' CPH Tool Bar Brace - Left Hand
	149-167H	20' CPH Tool Bar Brace - Right Hand
2.	802-064C	Screw, Cap Hex Head 3/4"-10 x 2" Long
3.	804-023C	Washer, Lock Spring 3/4"
4.	803-027C	Nut, Hex 3/4"-10
5.	149-165H	20' Tool Bar Support
6.	806-063C	U-Bolt 5/8"-11 x 4 1/32" x 7" Long
7.	804-022C	Washer, Lock Spring 5/8"
8.	803-021C	Nut, Hex 5/8"-11
9.	804-030C	Washer, Lock Spring 1 1/4"
10.	802-123C	Screw, Cap Hex Head 1 1/4"-7 x 2 1/2" Long
11.	149-586D	CPH Brace Kit Spacer

Great Plains Manufacturing, Inc.

Corporate Offices: PO. Box 5060
Salina, Kansas 67402-5060 USA
