

## Installation Instructions



### 705/1005 End Wheel No-Till Drill Calibration Kit

Used with:

- 705 End Wheel No-Till Drill
- 1005 End Wheel No-Till Drill



*When you see this symbol, the subsequent instructions and warnings are serious - follow without exception. Your life and the lives of others depend on it!*

## General Information

These instructions explain how to install the Calibration Kit Option.

These instructions apply to:

- |          |                      |
|----------|----------------------|
| 152-289A | 705 Calibration Kit  |
| 152-290A | 1005 Calibration Kit |

### Manual Update

Refer to the 705/1005 End Wheel No-Till Drill operator's manual for detailed information on safely operating, adjusting, troubleshooting and maintaining the calibration kit. Refer to the parts manual for part identification.

- |          |                   |
|----------|-------------------|
| 150-213M | Operator's Manual |
| 150-213P | Parts Manual      |

### Before You Start

Page 3 is a detailed listing of parts included in the Calibration Kit package. Use this list to inventory parts received.

### Tools Required

- Basic hand tools
- Welder

### Definitions

Right-hand and left-hand as used in this manual are determined by facing the direction the machine will travel while in use unless otherwise stated.

## Assembly Instructions

Refer to Figure 1

1. Loosen the drive chain tensioners on both the drive chains on the left-hand gauge wheel.
2. Rotate the left-hand gauge wheel until the roll pin (1) on the drive sprocket is in a position to be driven out. Drive out roll pin (1) and keep.
3. Use wire or clamp to hold the sprocket in place. There is no need to remove drive chain once the chain has been loosened.
4. Loosen the set screws (2) from both bearings.
5. Loosen the set screw (3) and remove the sprocket from the end of the jackshaft (4). You may need to remove the chain if loosening the tensioner does not allow enough slack for removal of the sprocket.

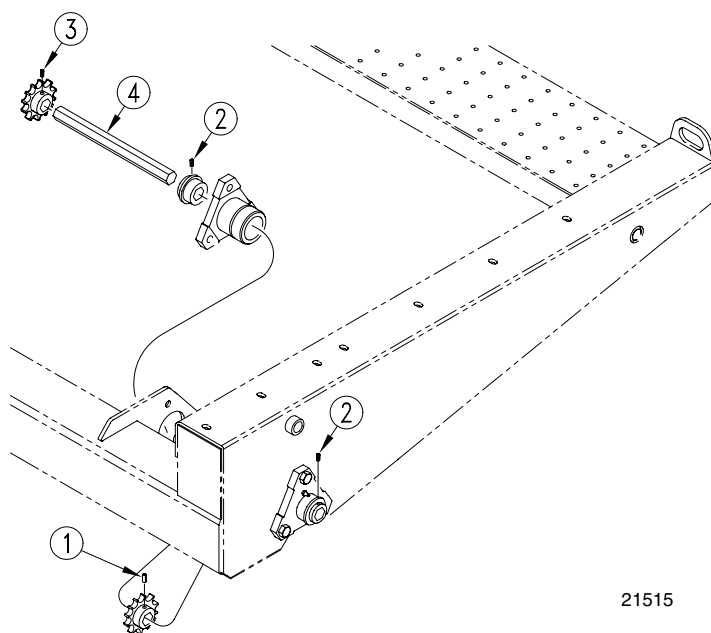

21515

**Figure 1**  
**Jackshaft**

## 2 Calibration Kit

6. Remove the old jackshaft (4) and replace it with the new one supplied in the kit. Use the new shaft to push the old shaft out. Position the new shaft so the end with the 9/32" hole is to the outside of the drill. Make sure the hole for the sprocket is turned the same direction as the hole in the sprocket to allow installation of the sprocket roll pin (1).
7. Align sprocket hole with the hole in the shaft and reinstall the roll pin (1). Position shaft and sprocket so the sprocket aligns with the sprockets on the tensioner.
8. Once the sprocket is aligned retighten the set screws (2) on the bearings to secure shaft in place.
9. Reinstall the sprocket on the end of the shaft and tighten the set screw (3). Retighten the drive chains.
10. Position the crank handle stob on the top side of the tongue and weld in place. Repaint the area with green paint (P/N: 821-001C) purchased from your Great Plains dealer.

Use the following instructions to check seeding rate.

1. Hydraulically lower drill to planting position to activate clutch.
2. Check that tires are 9.0 x 24 rib implement and properly inflated. Refer to "**Tire Inflation Chart**," page 35 in the operator's manual.
3. Jack drive (left) end wheel off ground. Rotate wheel to see that drive system is working properly and seed cups are free from foreign material.
4. Record weight of an empty container large enough to hold seed metered for one acre.
5. Place several pounds of seed over three seed cups on an outside end of the drill box. Pull the seed tubes off of these three openers.
6. Turn drive end wheel several times to fill seed-cups with seed. Turn wheel until seed falls to the ground from each cup.
7. Place container under the three tubes to gather metered seed.
8. Rotate drive wheel until 1 acre is tallied on acremeter. This will be 592 rotations on a 7-foot drill or 422 rotations on a 10-foot drill. You can also rotate the gauge wheel jackshaft by means of a wrench or socket or by means of the calibration handle stored on the tongue.

### Refer to Figure 2

9. If rotating gauge wheel jackshaft, disengage the lockout on the drive wheel and use same number of rotations as for rotating drive wheel. Check that the three seed cups have plenty of seed coming into them.
10. Weigh metered seed. Subtract initial weight of container. Divide by three. Multiply by the number of openers on your drill to determine total pounds seeded per acre. If this figure is different than desired, reset sprockets accordingly.

NOTE: You may want to repeat the calibration procedure if your results vary greatly from the seed-rate chart.

11. When drilling, check seeding rate by noting acres drilled, amount of seed added to drill and seed level in drill box. If you are seeding more or less than desired, adjust seeding rate slightly to compensate for field conditions.

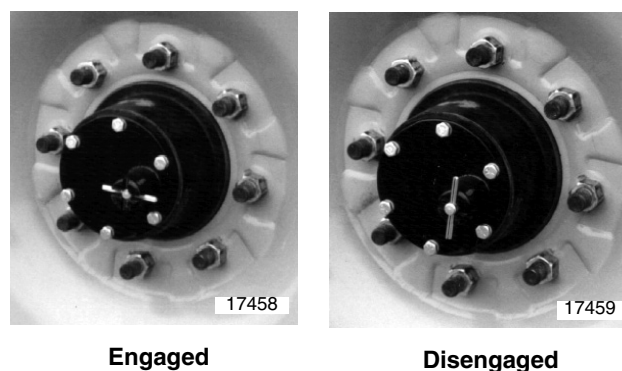

**Figure 2**  
**Drive Wheel Lockout**

---

### 152-289A 705 Calibration Kit

Your kit includes:

| Qty. | Part No. | Part Description           |
|------|----------|----------------------------|
| 1    | 152-278H | EWNT CALIBRATION HANDLE    |
| 1    | 152-291M | INSTRUCTIONS, CALIBRATION  |
| 1    | 152-538D | 705 NC GW JACKSHAFT        |
| 1    | 152-539D | HANDLE STORAGE STOB        |
| 1    | 805-093C | PIN COTTERLESS HITCH 1/4 X |

### 152-290A 1005 Calibration Kit

Your kit includes:

| Qty. | Part No. | Part Description           |
|------|----------|----------------------------|
| 1    | 152-278H | EWNT CALIBRATION HANDLE    |
| 1    | 152-291M | INSTRUCTIONS, CALIBRATION  |
| 1    | 152-506D | 100 NC GW JACKSHAFT        |
| 1    | 152-539D | HANDLE STORAGE STOB        |
| 1    | 805-093C | PIN COTTERLESS HITCH 1/4 X |