

## Update Instructions

---



### 2S-2600 2 Section Folding Drill Counterbalance Update

---

Used with:

- 2S-2600



*When you see this symbol, the subsequent instructions and warnings are serious - follow without exception. Your life and the lives of others depend on it!*

## General Information

---

The 2S-2600 drill uses a P.O. check in the opener lift circuit to lock the openers in the raised position. This P.O. check remains locked until the operator wants to lower the openers. When lowering, oil is supplied to the base end of the opener cylinders. Oil pressure builds on the base end of the lift cylinders until a pilot line signals the P.O. check to open.

By design, the P.O. check will open fully when it receives a pilot signal. When fully open, the openers, pulled by gravity are free to fall. During this free fall, if the oil supply to the base end of the opener cylinders is too slow to keep up, the oil pressure drops and the pilot signal tells the P.O. check to close. Once the P.O. check closes, oil from the tractor can "catch up". Pressure builds and the P.O. check opens again. This locking and unlocking can happen several times as the openers are lowered.

A new counterbalance valve replaces the P.O. check. Instead of going to full open when the valve gets its pilot signal, the counterbalance valve will only partially open. The opening is proportional to the pilot signal. The counterbalance valve allows the operator to push the openers down in a smooth, controlled motion.

These instructions apply to:

195-297A 2600 Counterbalance Valve Update

### Manual Update

A copy of the updated parts manual is available through your Great Plains dealer.

Refer to the 2S-2600 operator's manual for detailed information on safely operating, adjusting, troubleshooting and maintaining the 2S-2600. Refer to the parts manual for part identification.

195-200M-A Operator's Manual

195-200P Parts Manual

### Before You Start

Page 7 is a detailed listing of parts included in the Counterbalance Valve Update. Use this list to inventory parts received.

### Tools Required

- Basic hand tools

## Assembly Instructions

### Overview of Installation Process

Refer to Figure 1

The new counterbalance valve will hang under the center pressure reducing valve (1), in the exact location where the P.O. check valve (2) is being removed.

The pilot signal hose (3) will be reused, however the pilot signal will be pulled from a different location. The hose will be temporarily removed and reinstalled in a different location.

The new counterbalance valve body is thicker than the old P.O. check. Because of this the center pressure reducing valve (1) will need to be shimmed out with washers to make room for the new valve. To add washers under the center pressure reducing valve (1) the wing pressure valve (4) will need to be unbolted and pulled out of the way. The plumbing to the center pressure reducing valve (1) does not need to be disturbed.

Once the new counterbalance valve is installed the drill needs to be raised and lowered so the valve can be checked and adjusted, if necessary. Refer to "Adjusting the Valve", on page 6 of this manual.

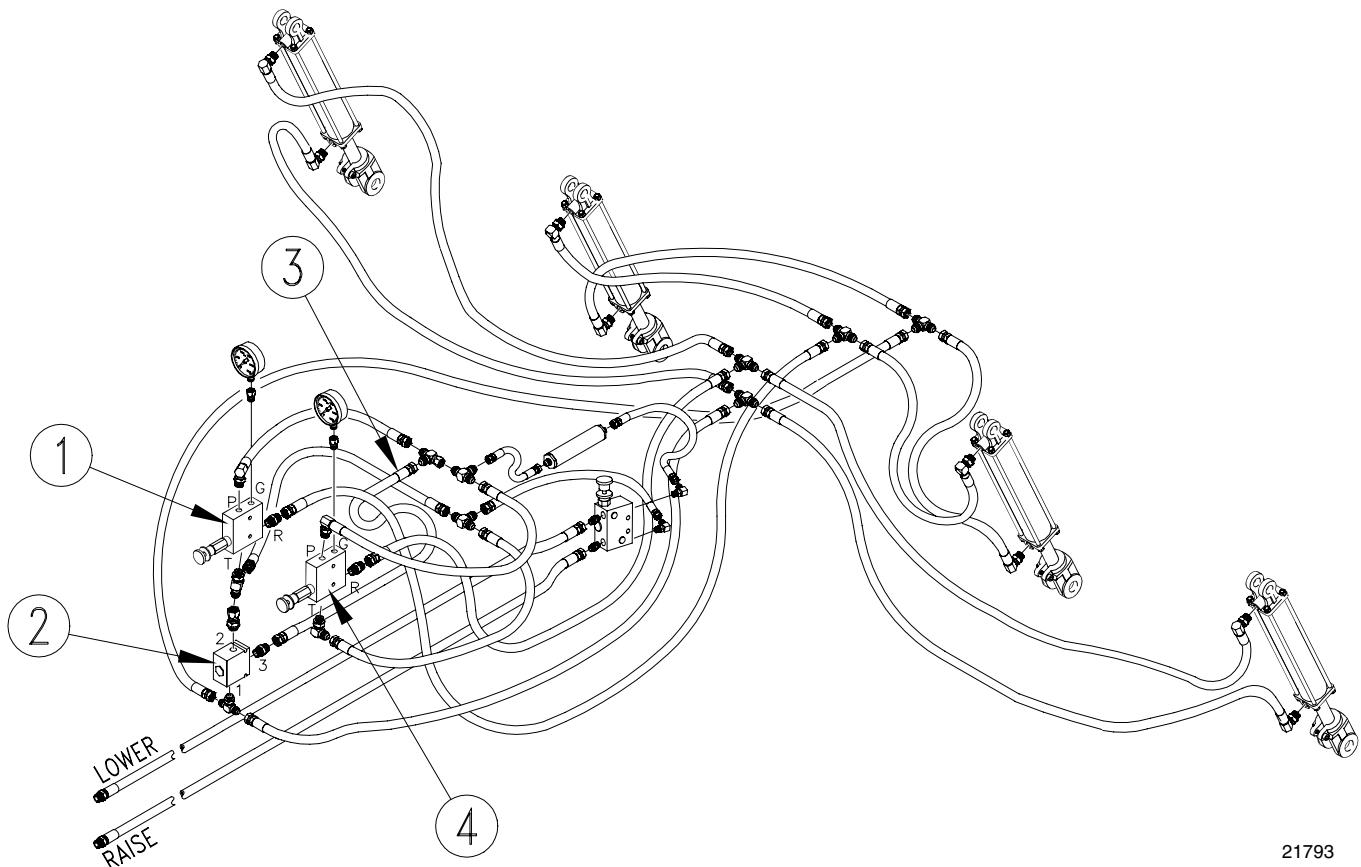

21793

Figure 1  
Original Plumbing Before Removing P.O. Check (No Point Row, No Open Center Kit)

## Installing the Valve

### Preparation

Hook the drill to a tractor. Move the opener lock handles to "Field", unfold the drill and lower the openers to the ground. Place the remote lever in float position to relieve any residual hydraulic pressure. Place tractor in park, turn off engine and remove the key before performing any maintenance on the drill. Clean the area around the pressure reducing valves by washing or using compressed air.



### WARNING!

*If using compressed air to clean around the pressure reducing valve make sure and keep others out of the area and always wear safety goggles and face shield.*

### Disassembly

*Refer to Figure 2*

1. Remove hoses (5) and (6) from the tee on the bottom of the P.O. check valve (2). Curl the hoses back towards the drill boxes and temporarily secure them out of the way.
2. Loosen both ends of pilot hose (3) and remove it from the drill. Save this hose for reuse.
3. Remove tee (7) from between tee (8) and hose (9). Install hose (9) right back on tee (8) and tighten. Keep tee (7) for reuse.
4. Remove the P.O. check valve (2) by taking fitting (10) off of tee (11).

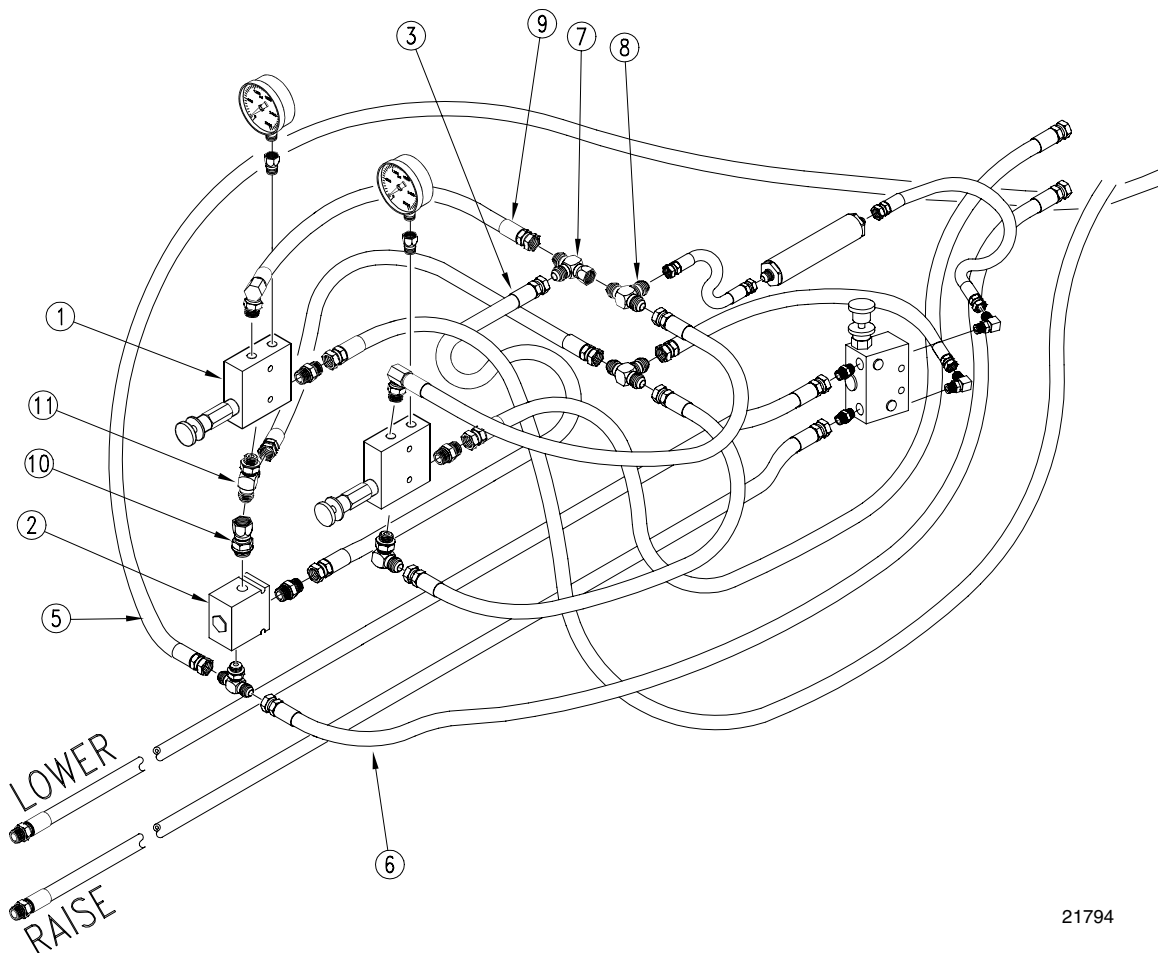

21794

**Figure 2**  
**Disassembly**

## 4 Counterbalance Update

**Installing Fittings on New Counterbalance Valve***Refer to Figure 3*

1. Transfer fitting (10) from the P.O. check valve (2) to the counterbalance valve (12), port 2.
2. Install new elbow (13) and tee (14) on port 1.
3. Install new elbow (15) on port 3.

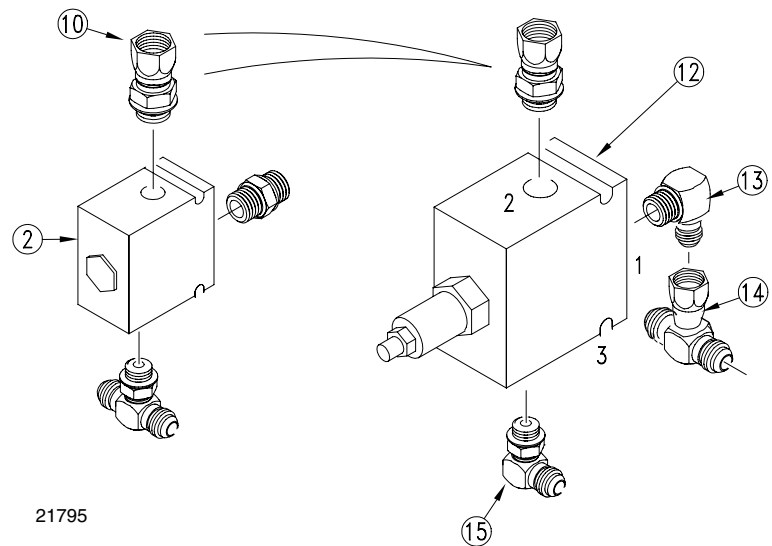

**Figure 3**  
**Installing Fittings**

**Shimming the Center Reducing Valve***Refer to Figure 4*

1. Remove the mounting bolts for wing reducing valve (4) and rotate the valve out of the way. Do not remove any plumbing from this valve.
2. Remove the mounting bolts for the center reducing valve (1). Reinstall the bolts, placing four flat washers (16) against the valve's body to shim it away from the mounting bracket.
3. Reinstall the reducing valve (4).

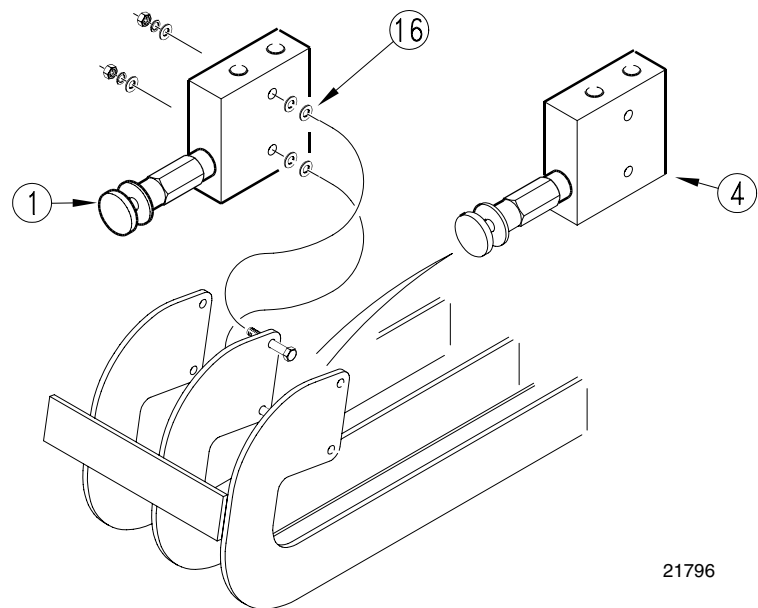

**Figure 4**  
**Shimming**

**Install the Valve and Finish the Plumbing***Refer to Figure 5*

1. Install the counterbalance valve (12) on the drill by connecting fitting (10) to tee (11).
2. Install tee (7), removed in step 3 on page 3, between fitting (17) and hose (18). This will be the new pilot line source.
3. Reinstall the pilot line hose (3) between tee (7) and elbow (15).
4. Reinstall hoses (5) and (6) on tee (14).
5. This finishes the plumbing. Tighten all fittings and hardware.

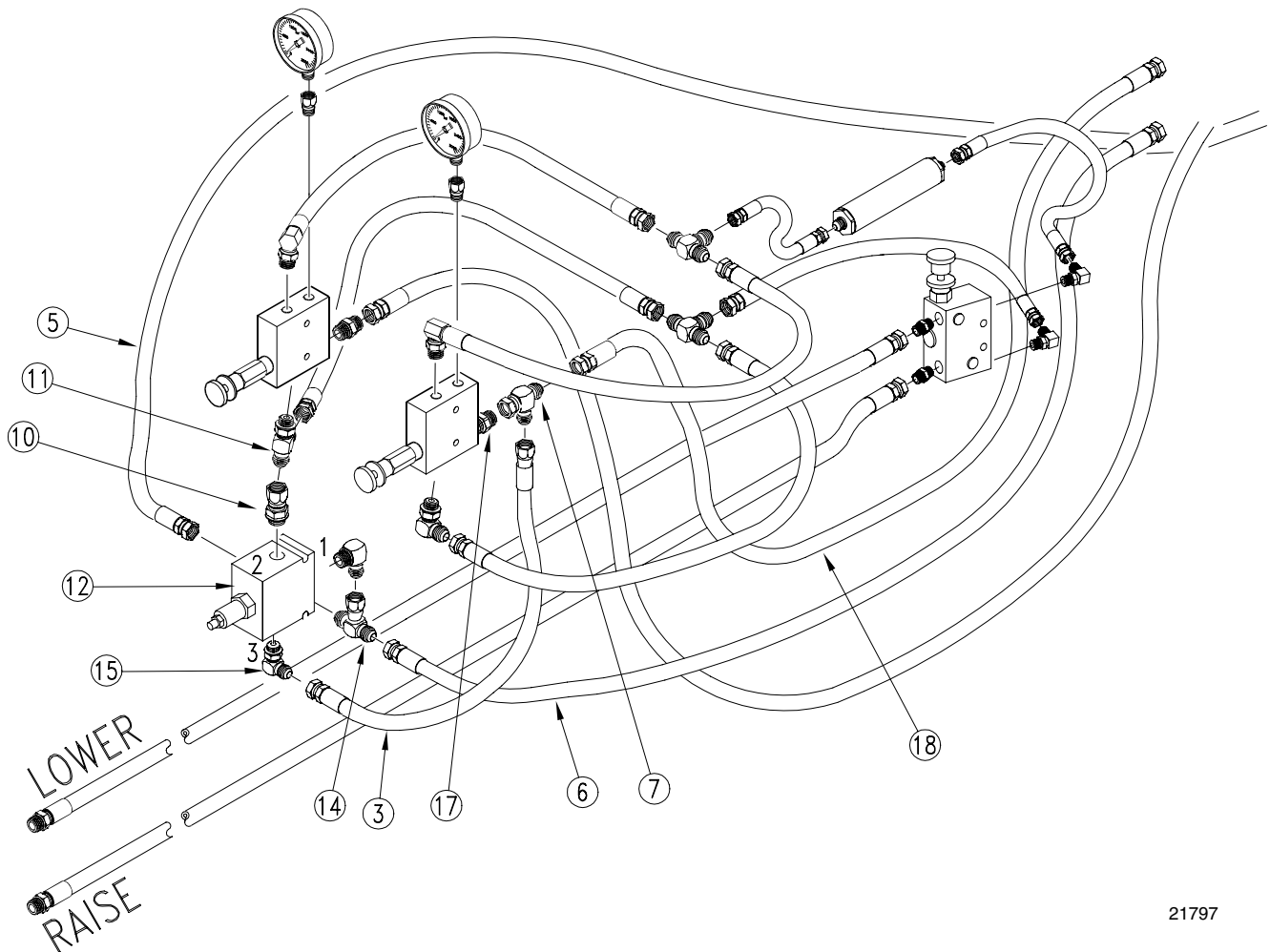

21797

**Figure 5**  
**Installing the Valve**

## Adjusting the Valve

On the stem of the valve there is a rubber cap that protects the threads of an adjustment stem. This stem is locked in place with a hex nut. To adjust the valve, loosen the nut and turn the stem using an Allen wrench.

Screwing the stem in (clockwise) pushes on a spring which supplements the pilot line's force on an internal piston. More spring force will let the valve open with a low pilot pressure. Less spring force will require higher pilot pressure to open the valve.

Note: With the screw turned in fully, the spring will develop enough force on the piston to unlock the valve, even with no pilot pressure, causing the openers to settle.

Raise and lower the drill several times then hold hydraulic down pressure on the openers to purge air from the system and to warm the oil. Repeat.

Raise the openers. Observe the openers closely to detect settling. If the openers remain up, no valve adjustment is needed.

If the openers settle, the stem is screwed in too far. Gently back the stem out until it stops, then screw it in one turn. Generally this is a good starting point. Check for settling.

Backing the stem out will lock the valve, screwing it in too far can cause it to unlock.

A small increase in lowering speed can be achieved by screwing the stem in.

## 2S-2600 November 2003 and later Plumbing Diagram. (no point row or open center kit)

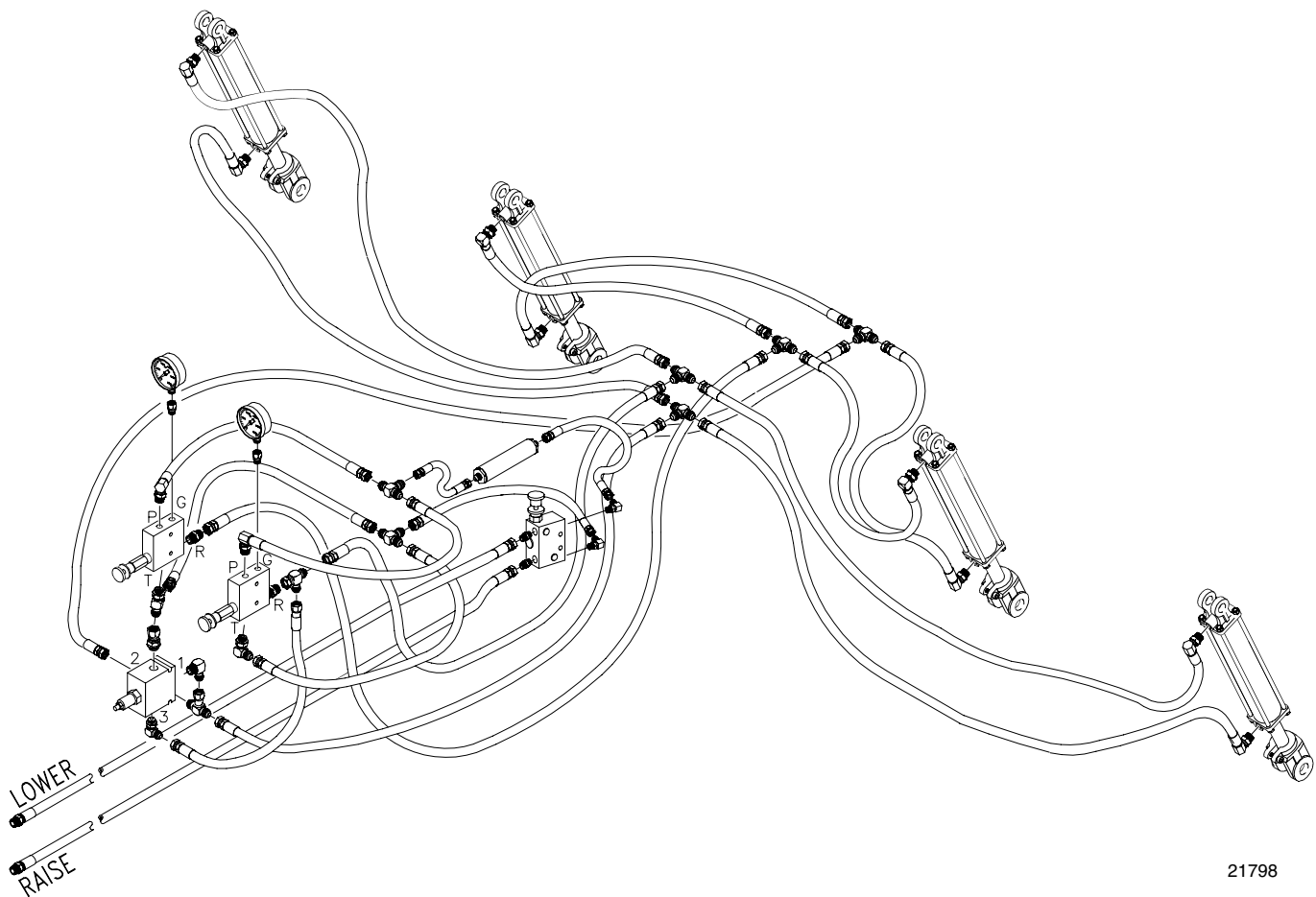

21798

---

## 195-297A 2600 Counterbalance Valve Field Update

Your kit includes:

Qty.	Part No.	Part Description
1	195-298M	MANUAL 2600 COUNTERBALANCE VALVE UPDATE
4	804-010C	Washer FLAT 5/16 USS PLT
1	810-523C	VALVE COUNTERBALANCE 10:1 9/16FOB
2	811-065C	EL 9/16 MJIC 9/16 MORB
1	811-193C	TEE 9/16 FJIC 9/16 MJIC